



NEW ERA & TOP SAFETY
HKTC Aerial Lift & Bucket Truck

Aerial Lift & Bucket Truck

By manufacturing innovative lifting equipment to provide not only accessibility but also safety, HKTC continues to share new experiences and values we make to you.

Durable boom & Best performance

All octagonal booms made by high-tensile steel, ATOS 80 are designed to maximize durability in perfect working order, which is essential to operator's safety.

Safety-oriented Design

Unquestionably, safety is the first, last and always to aerial Lift & Bucket truck. By applying higher capacity slewing bearing, which is playing a pivotal role just like your waist, safe and efficient working condition can be guaranteed. All components, parts and system are designed by 3D Modeling in order to minimize the technical error.

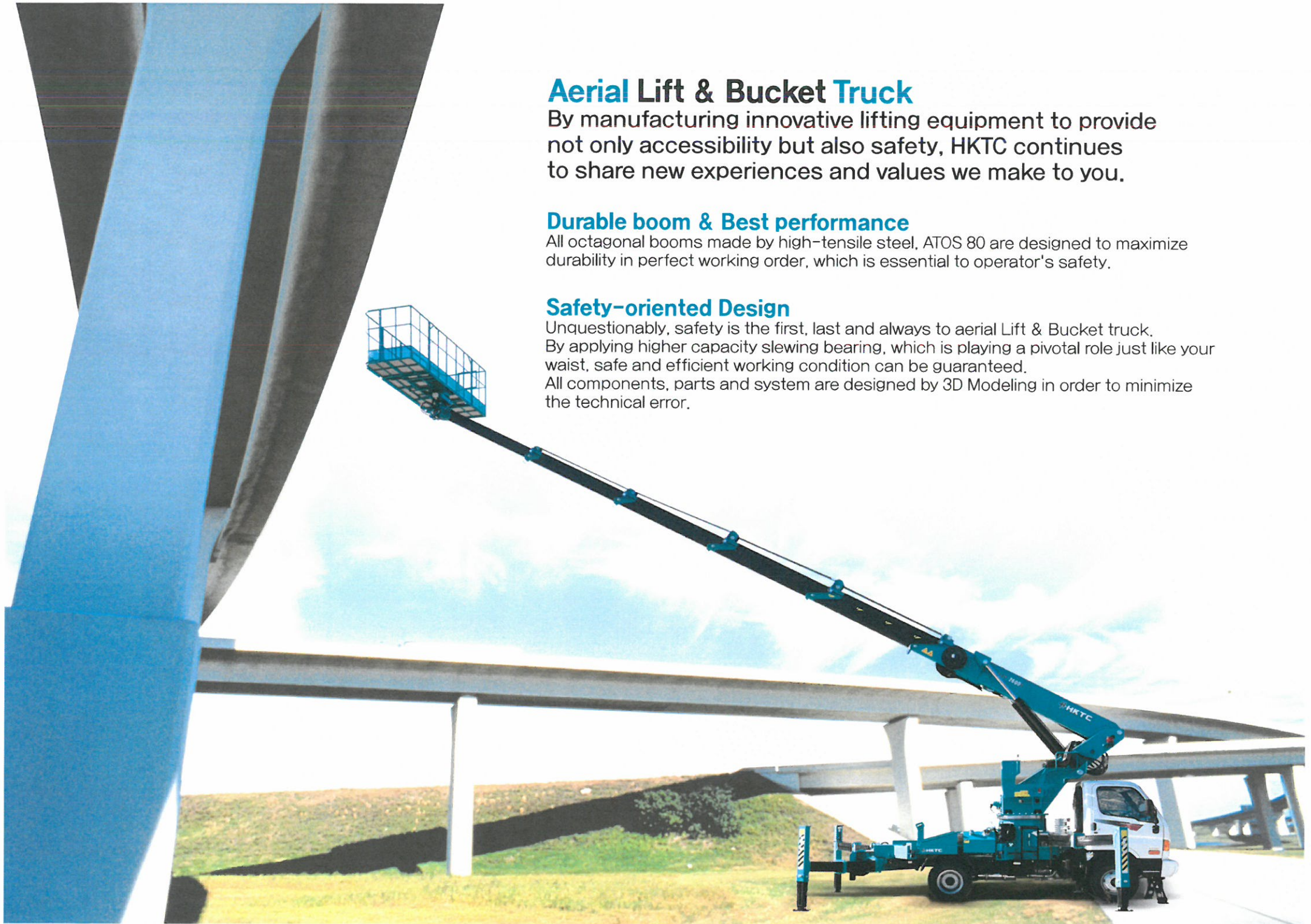



Remote Controller

Hetronic's remote controller can improve work efficiency. Working condition can be checked through liquid crystal display.



Top Seat Console

Optimally & ergonomically designed top seat console guarantees all day comfort.



Expandable Bucket

To improve safety, there are guardrails and Bucket can be expanded for the working convenience. Optionally market-oriented bucket can be replaced.

Automatic levelling system

Automatic levelling system of Bucket allows safe operation by setting bucket at level.



Slewing Reduction Gear

Smooth and safe operation can be made by high capacity worm-gear reduction gear. There is no damage incurred by external shocks as it is located under the boom.

Galvanization

All Components are fully galvanized to prevent Rust.

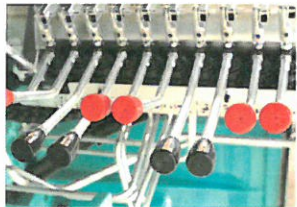

Outrigger Lever

Outrigger levers at both sides can offer the maneuverable and convenient operation.



Bucket tilting over center valve

By high-quality bucket tilting over center valve, durability is improved. It can prevent Bucket falling down.



Oil Cooler

To minimize heat loss during the operation, high-value oil cooler can guarantee optimal performance.



Emergency Pump

At malfunction or failure of hydraulic system, Emergency pump can guarantee to lower the operator into the bucket safely.



Chain-interlocked Boom

To minimize vibration of booms, during the aerial work, all booms are interlocked by chain.



Outrigger

2 staged Outrigger can provide longitudinal & directional stability. Optionally, H-Type can be replaced.

Aerial Lift / Bucket Truck (HAP-2600S & 2800S)

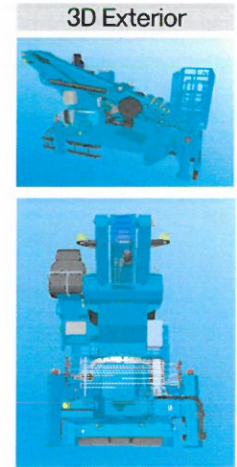
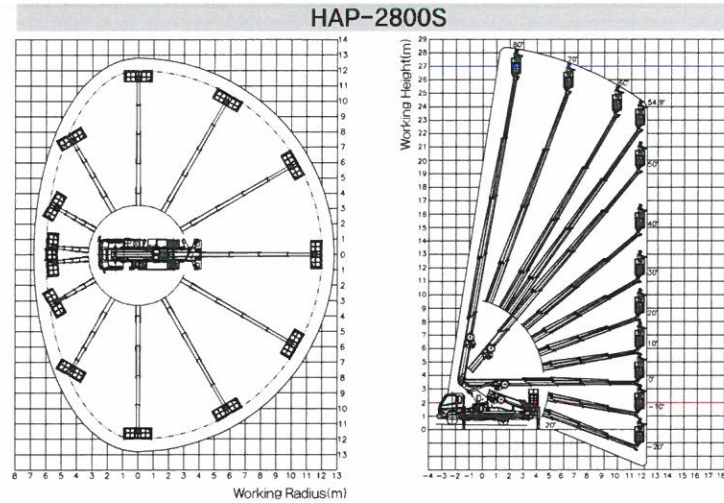
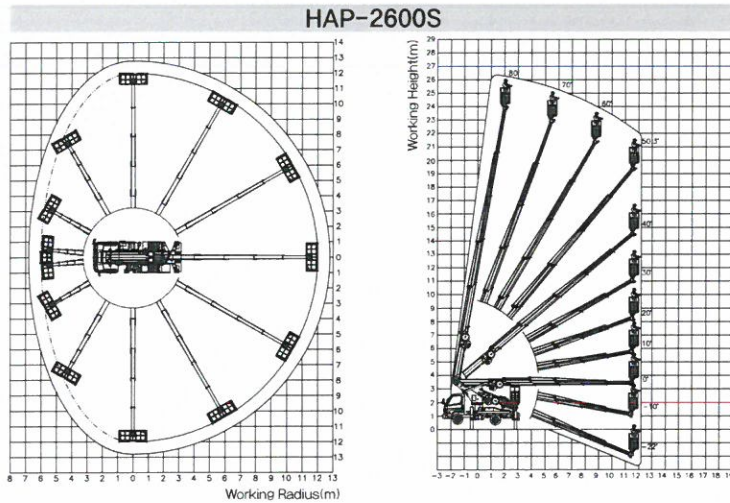

Description		HAP-2600S	HAP-2800S	Remarks
Rated Load (Bucket)		400 kg.f		
Height	Maximum working height	26.3 m	28.5 m	From Ground to bottom of Bucket
	Bucket height	24.3 m	26.5 m	
Rated Oil Flow		63 l / m		1,000 rpm basis
Oil Tank Capacity		110 l		
Slewing	Type	Worm reduction gear and Hydraulic Motor.		Uncontinuous
	Angle	350°		
	Speed	1.2 rpm		
Boom	Section	6	5	
	Type	Octagonal		
Outrigger	Main	X type / 5.9m / Hydraulically and automatically.		H-Type & Front outrigger (Optional)
	Rear			
Bucket	Type	Expandable		Uncontinuous
	Rotation	360°		
Operation		By levers and remote controller		Dual operation
Safety devices		Safety Valve (Relief Valve), Over-center valve, Over hoist prevention device, Double over-center valve, Winch automatic brake, Double pilot check valve, Safety hook, Fuse Valve, Automatic Moment Limiter		
Optional		Winch for crane work / Inverter		
Recommendable Truck chassis		more than 3.5 ton		

Remarks

1. The specifications are subject to change without any prior-notice, according to product improvements.
2. The separate Contract with his own specification sheet prevails the above-mentioned Specification.
3. Automatic Moment Limiter is optional for overseas markets, according to customer's requirement.

www.hktc.co.kr



HanKook Tower Crane Co. Ltd
 1191, Chopyeong-ro, Chopyeong-myeon, Jinchun-gun, Chungbuk, Korea
 TEL +82-70-4487-8030 FAX +82-43-838-5353 E-mail snha@hktc.co.kr